

Caratteristiche - Specifications - Caractéristiques - Características

IN	Ø	1" BSP
	Press. Min.	-0,1 bar (-1.5 PSI)
	Press. Max.	6 bar (87 PSI)
	Temp. Max.	74°C (165°F)
OUT	Ø	1/2 BSP
SHAFT	Ø	30 mm
OIL	SAE 75W 90	1,5l (0.4 U.S.gal.)
WEIGHT	kg (lbs)	20,5 kg (45.2 lbs)

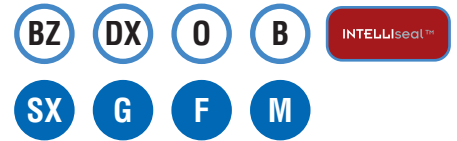

Codice Code	Modello Model	Press. Max Max Pressure		950 RPM				1450 RPM				1725 RPM				Pistone Plunger	Corsa Stroke
		bar	PSI	l/min	GPM	kW	hp	l/min	GPM	kW	hp	l/min	GPM	kW	hp		
08.1042.97.A	RBL 4219-P	190	2755	27	7,1	10,2	13,6	42	11,1	15,4	20,6	49	12,9	18,1	24,3	25	21
08.1004.97.A	RBL 5019-P	190	2755	33	8,7	12,2	16,4	50	13,2	18,5	24,8	-	-	-	-	25	25

RBL Premium



GRAFICO PRESTAZIONI - PERFORMANCE CHART



Accessori di completamento - Complementary accessories Accessoires complémentaires - Accesorios complementarios

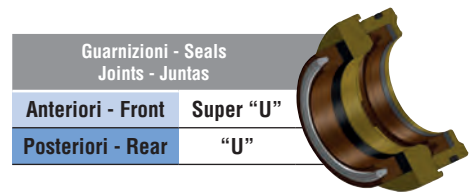
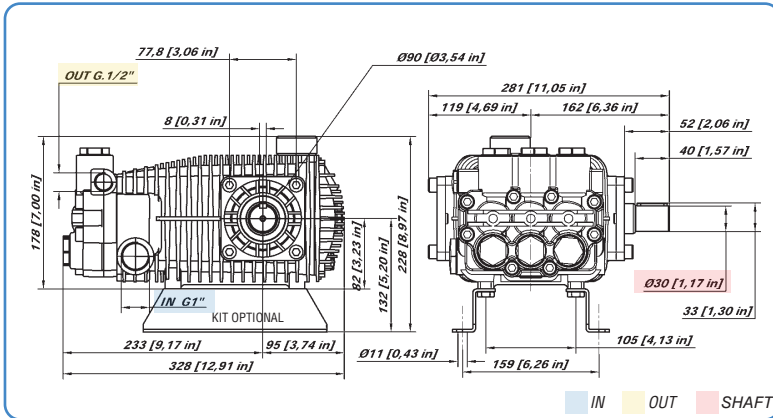
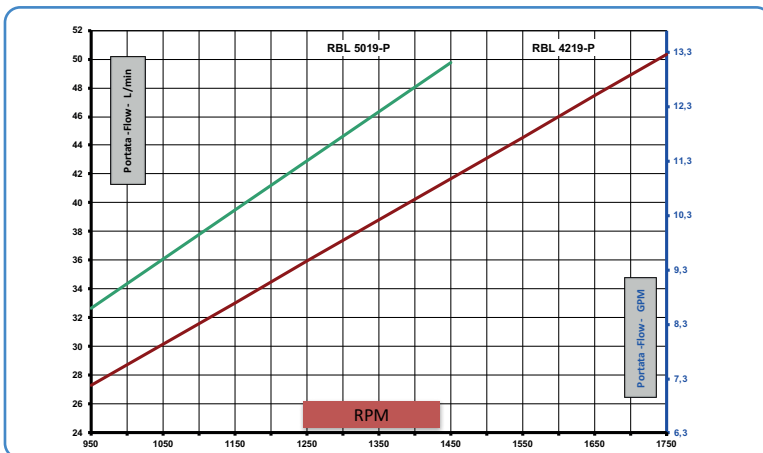